

RAPTOR® & RAPTOR® REX™

By **AIR AMERICA®**

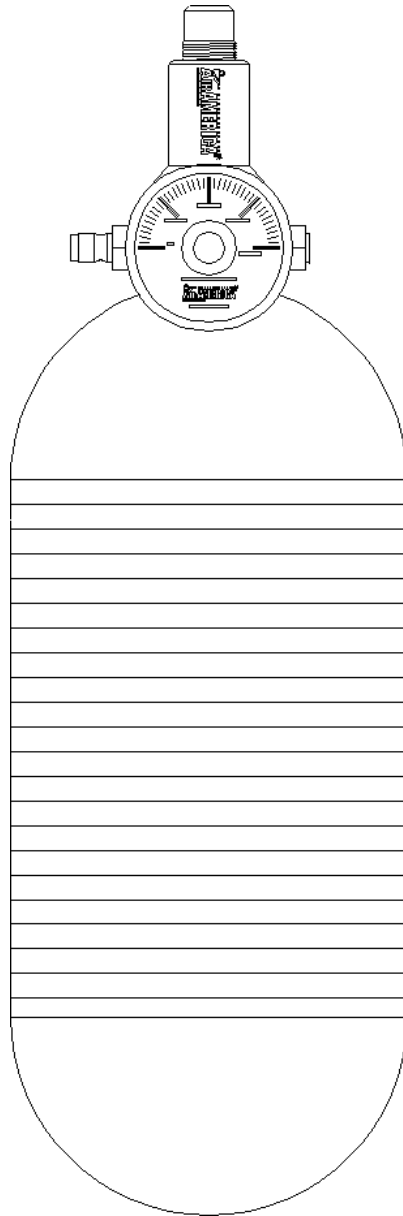



GENERAL INFORMATION

RAPTOR® & RAPTOR® Rex™

With unparalleled consistency and performance the RAPTOR® (MAX 3000 PSI) and RAPTOR® REX™ (MAX 4500 PSI), is designed and engineered to deliver fully adjustable output pressures from 200 to 1000 PSI to your marker. The RAPTOR®'s are totality compatible with *virtually all* of the markers currently sold. Precision machined from solid stainless steel and backed by the Air America® Limited lifetime warranty, the RAPTOR® will deliver a lifetime of safe, rugged, reliable service, along with the razors edge performance expected from an Air America® system.

SAFETY ALERT!!

**ALWAYS DE-GAS YOUR SYSTEM
BEFORE YOU SERVICE OR REPAIR YOUR RAPTOR®.**

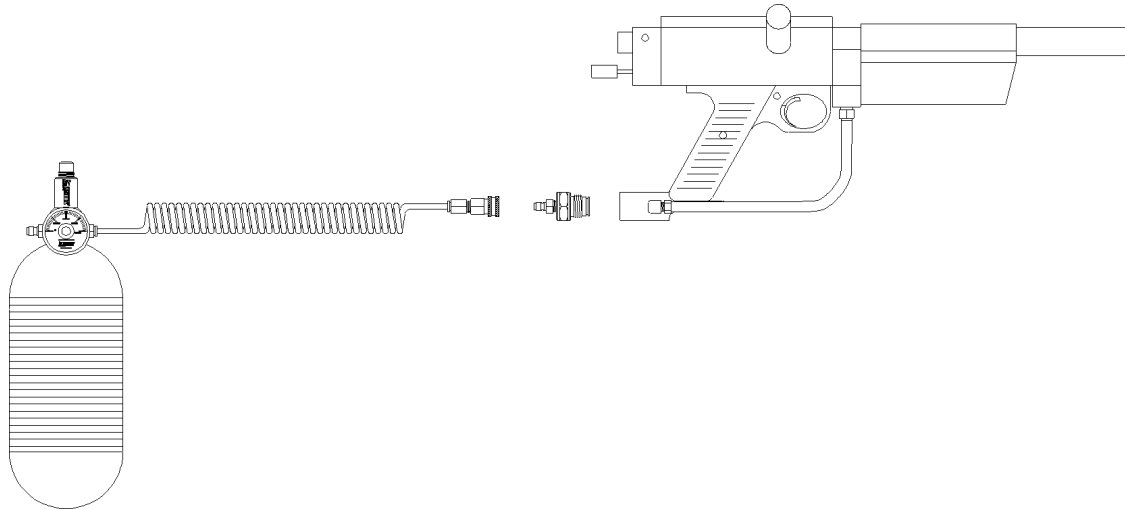

REMOTE CONFIGURATION

The above illustration demonstrates one of the many installation options available if you are using your RAPTOR® in a remote configuration. When selecting the appropriate ASA fitting, adapter, and remote hose, **SAFETY** should be your #1 consideration. All fittings, adapters, and hoses must be ***WORKING PRESSURE RATED**.

4 times the **minimum burst pressure of the components and accessories, related to the specific application, is the U.S. accepted standard for the minimum **WORKING PRESSURE RATING**.*

ON-MARKER CONFIGURATION

Since the introduction of the RAPTOR® system there has been a number of aftermarket cradle mounting devices and mounting kits designed specifically for the RAPTOR®. Your local Field/Retailer can help you choose which mounting system will work best for you.

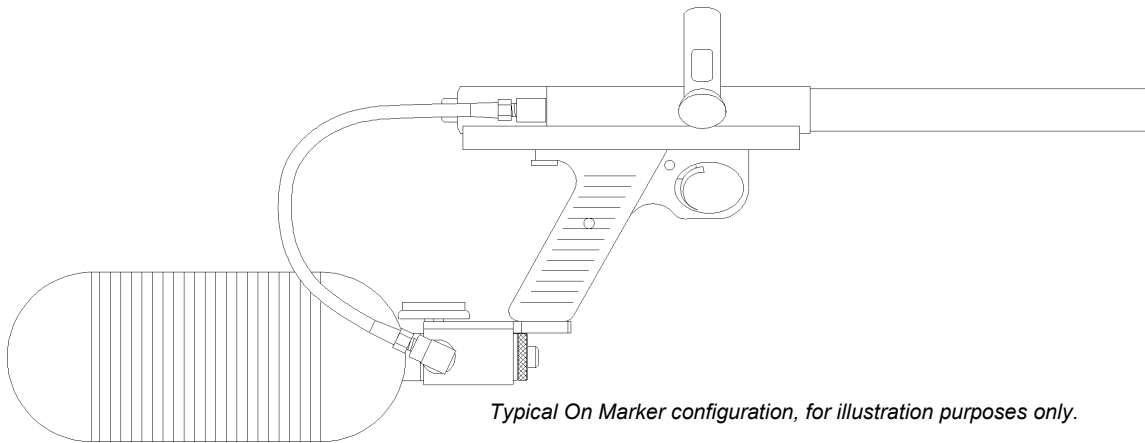

Typical On Marker configuration, for illustration purposes only.

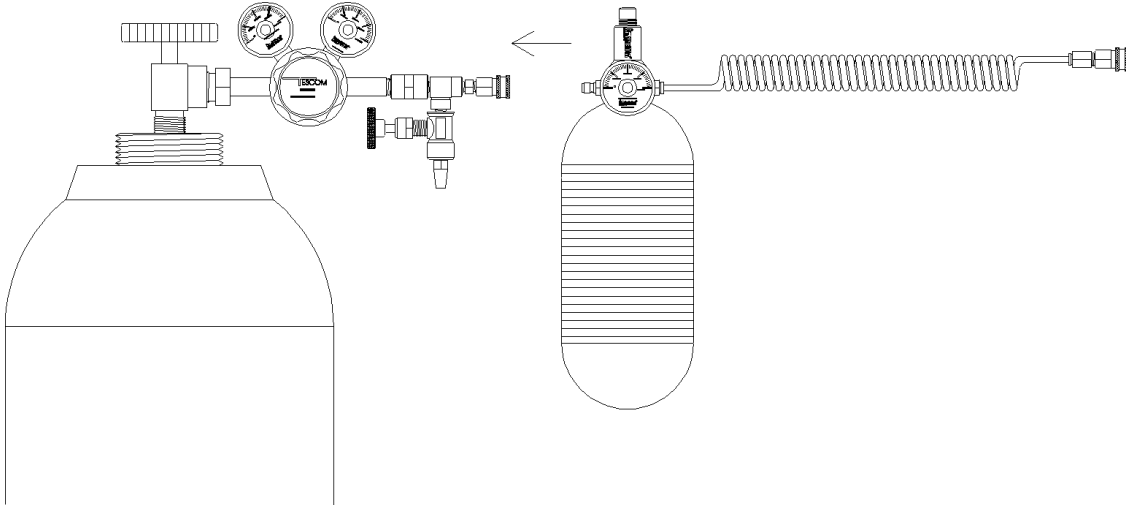

Typical fill station configuration, for illustration purposes only.

FILLING THE SYSTEM

The Air America® Quickfill™ fitting on your RAPTOR® system, the *Male* quick disconnect labeled "**IN**", *opposite* the output port, is rated for use at 4500 PSI and is the accepted standard fail safe fitting used throughout the world of Paintball. If you have your own fill station, connect your RAPTOR® to the fill station system and follow the directions that pertain to your fill station. Your local Field or Paintball store is equipped to fill your RAPTOR®.

INITIAL ADJUSTMENTS

Your RAPTOR® left the factory set for an output pressure of 750 PSI. This is a good, average setting. You may alter this setting if your marker requires a different delivery pressure.

The operating pressure your marker requires for maximum performance is delivered to your marker through the Adjusting Screw on the top of the RAPTOR®. You will need a 3/16 Allen key for this operation. Turning the Adjusting Screw in, a **maximum of ¼ turn** for each adjustment, ⤵ (clockwise) as you face the top of the regulator, **increases** the pressure, and turning the Adjusting Screw out ⤴ (counterclockwise) a **maximum of ¼ turn**, **reduces** the delivered operating pressure to your marker.

Note: If you are increasing or decreasing the pressure setting, cycle your marker several times after each adjustment. This allows the marker and system to adjust to the new pressure setting.

DO NOT REMOVE ADJUSTING SCREW IF YOUR TANK CONTAINS ANY PRESSURE.

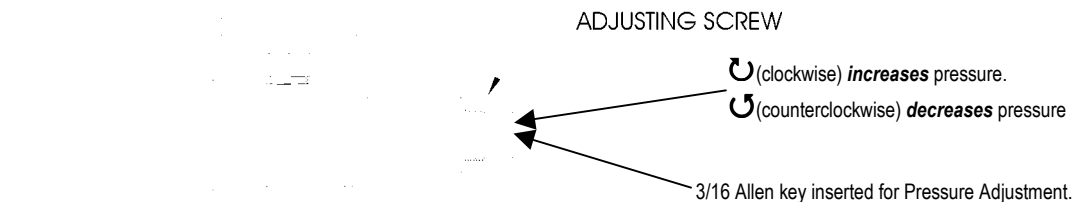

If you are shooting a stock Automag, 750 PSI should be the proper pressure setting. For other stock markers, your best delivery pressure will probably be between 700 and 850 PSI. Always check with your marker manufacturer for the safe and proper pressure setting of your marker.

SERVICING YOUR RAPTOR®

Your RAPTOR® has been engineered to require an absolute minimum amount of servicing. Air America® will service your equipment under your Air America® Limited Lifetime Warranty, upon request. The following section has been included for those individuals who prefer to do their own service/maintenance.

Your RAPTOR® can be completely disassembled with a 3/16 Allen key, a 7/16 open-end wrench, and an adjustable wrench or small strap wrench. You should note however, that complete disassembly is rarely required. There are two basic service areas; the Piston/Spring Pack area, and the regulator Seat and Pin Valve area. Either one of these areas can be serviced without disturbing the other.

The following chart and exploded drawing will assist you in diagnosing/trouble-shooting your RAPTOR®.

PROBLEM	POSSIBLE CAUSE
No Gas Delivery	Adjusting Screw not set. Deformed Valve Seat. Internal obstruction.
Shoot Down	Pressure not set high enough for specific marker. Deformed Valve Seat. Regulator Piston "O" ring damaged. Bent/Damaged Pin Valve. *Bad Air
Erratic Delivery Pressure	Regulator Piston "O" ring damaged. Worn regulator Seat. Bent/Damaged Pin Valve. *Bad Air
Output Pressure Unstable	Deformed regulator Seat. Dirt in regulator Seat/Pin Valve error. Damage to sealing face on regulator Pin Valve. Bent/Damaged Pin Valve. *Bad Air
Quickfill™ Fitting Air Leak	Damaged or dirty "O" ring on the Quickfill™ check strut. *Bad Air
Gas Venting From Adjusting Screw	Output pressure set too high. (Safety is performing it's normal function.) Defective regulator Seat. Defective Pin Valve. Damaged or dirty Piston "O" rings. *Bad Air

*Bad Air; the presents of compressor oil, moisture, foreign particles, and debris, from collapsed or compacted compressor filters are a major cause of system malfunctions.

SAFETY ALERT!!
ALWAYS DE-GAS YOUR SYSTEM
BEFORE YOU SERVICE OR REPAIR, YOUR RAPTOR®.

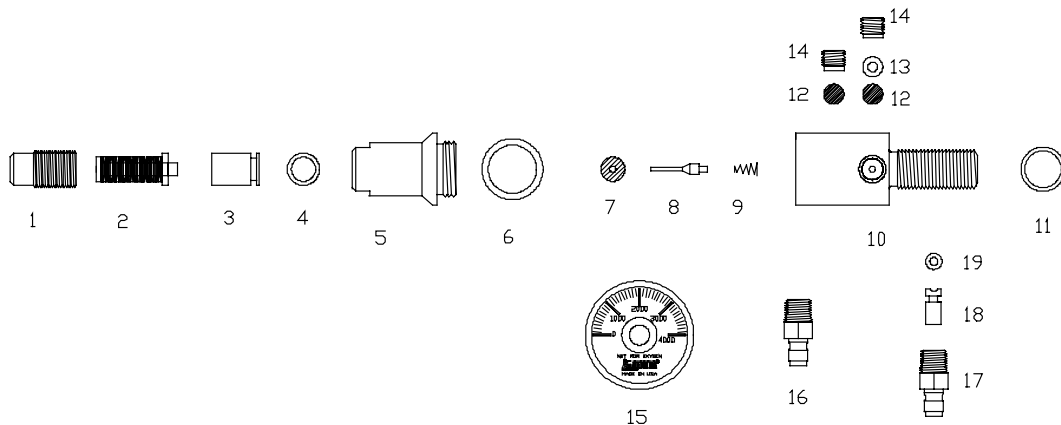

- | | |
|-----------------------------------|---------------------------------|
| 1. REGULATOR ADJ. NUT | 12. BURST DISK |
| 2. SPRINGPACK | 13. ORIFICE WASHER |
| 3. PISTON ASSEM. | 14. SAFETY RETAINING SCREW |
| 4. PISTON O RING (012-90) | 15. HP GAUGE |
| 5. PISTON HOUSING | 16. MALE QD |
| 6. PISTON HOUSING O RING (116-90) | 17. MODIFIED MALE QD |
| 7. REGULATOR SEAT | 18. CHECK STRUT |
| 8. REGULATOR PIN VALVE | 19. CHECK STRUT O RING (006-90) |
| 9. CONE SPRING | |
| 10. GAS DISTRIBUTION BODY | |
| 11. BOTTLE O RING (015-90) | |

SERVICING THE PISTON AND SPRING PACK ASSEMBLIES

The Piston and Spring Pack can be removed for service by unscrewing the Adjusting Screw nut completely. The Spring Pack can be withdrawn easily, and the Piston can be pulled out of the Piston Housing with the aid of an "O" ring pick, or sturdy piece of steel wire with a small hook on the end of the wire.

Normally, the only wear item in this group is the Piston "O" ring. A periodic replacement of this "O" ring is recommended. Before reinstalling a new "O" ring, make sure the "O" ring groove in the Piston is clean.

Once you have the Piston out of the Piston Housing, the Piston Housing bore should be cleaned. Insert a piece of lint free cloth into the bore and rotating gently. If you are only working on this portion of the regulator, and have not disassembled the rest of the unit, care should be taken to avoid bending the Pin Valve, which can be seen extending through the center hole in the bottom of the bore.

To reassemble, lube the Piston "O" ring lightly with 10W 30 motor oil, and gently push it back into the Piston bore. Lubricate the Spring Pack assembly with a few drops of 10W 30 motor oil and insert into the Piston bore. The reassemble of the Piston and Spring Pack Assemblies will be completed with the light application of white lithium grease on the Adjusting Screw Nut threads, finally turn the Adjusting Screw Nut in  clockwise, **hand tight**.

SAFETY ALERT!!

ALWAYS DE-GAS YOUR SYSTEM

BEFORE YOU SERVICE OR REPAIR, YOUR RAPTOR®.

SERVICING THE REGULATOR SEAT AND VALVE PIN

To service these components, it is necessary to separate the two halves of the RAPTOR®. If the system is being used on-marker, it must be removed from the marker.

Using an adjustable wrench, small strap wrench, or a vise, with leather padded jaws, grasp the wrench flats on the Piston housing and unscrew and separate the two halves of the RAPTOR®. Once these components are separated, the Valve Pin can be inspected and regulator Seat replaced. Caution; if you find it necessary to use a pick to remove the regulator Seat, be careful not to damage the regulator Body by scratching or chipping the metal sealing surface of the regulator Body. When reassembling the new Seat be aware that it is *tapered*, and must be installed "WIDE" side DOWN, in the Seat pocket, in the Piston Housing half of the RAPTOR®. You will note that the new Seat does not fit the pocket as tightly as the old one you removed. This is because the Seat "upsets" slightly when the two halves of the RAPTOR® are torqued together.

The sealing face of the Valve Pin should be free of nicks and scratches. If your Valve Pin appears to be marred in any way, replace it.

Tuning the system

THE RAPTOR® AND THE AUTOMAG

When the *RAPTOR*® is mated to the Automag's internal regulator a true, functioning, dual stage regulated system is created. The *RAPTOR*® should be set to deliver approximately 700 PSI to the Automag's internal regulator. The Automag's internal regulator then reduces the *RAPTOR*® incoming regulated 700 PSI to the Automag's typical working pressure of approximately 375 PSI. The minimum pressure your *RAPTOR*® should deliver to your Automag's regulator should be no less than 625 PSI.

ADVANCED TUNING OF THE RAPTOR® FOR THE AUTOCOCKER

For maximum, tournament level performance, the Autococker requires a dual stage regulated air/nitrogen system. The Air America® Vigilante™, Black Ice™, Violator™, or the Prophecy™ will enable you to upgrade your Autococker to a razor sharp, tournament level, dual stage regulated system when joined with your *RAPTOR*®.

Tuning of the Autococker's is accomplished by creating a balanced set of pressures within the Autococker itself. Valve design, valve and hammer spring energy, and air chamber size and pressure, are crucial elements in achieving maximum performance from your Autococker.

Example: If the hammer spring energy is set to high for the air chamber internal pressure then the duration of valve open time will be increased beyond its useful point. If the air chamber pressure and/or the valve return spring energy is too high then the amount of valve lift needed for proper flow will not occur. These examples illustrate how performance is diminished when internal pressures are not properly tuned.

The following is an overview of how to tune your system to achieve maximum efficiency. Different combinations of springs, valves and modifications will give you a variety of results, keep in mind this is only an overview. Your particular marker, depending on its modifications may react differently.

If you are using a secondary regulator: the Air America® Vigilante™, Black Ice™, Violator™, or the Prophecy™, to create a dual regulated system, you must first set the regulated outlet delivery pressure of your Raptor® to a minimum of approximately 750 PSI. At 750 PSI the secondary regulator will have sufficient pressure to function properly. The secondary regulator can be accurately adjusted with the use of the Air America® Guardian™ universal tester. Once this is done all the adjustments described below will be made at the secondary regulator. If you choose to utilize your Raptor® system as the only regulator then follow the procedure outlined below, making your adjustments at the Raptor®.

NOTE: When *INCREASING* the output pressure of your *RAPTOR*® the Regulator Adjustment Nut is *SCREWED IN*, ⤵ in ¼ turn increments, (clockwise) or when *DECREASING* the output pressure, *SCREWED OUT*, ⤴ in ¼ turn increments (counterclockwise) dry fire the marker several times after each adjustment to equalize the pressure in the system.

Step 1. Begin by turning the hammer spring adjustment on your marker all the way out to the *minimum* setting.

Step 2. Decrease the output pressure on the Raptor® to the “no flow” point. If you are using a secondary regulator, (dual staged) this procedure should be done at the secondary regulator only.

NOTE: The term “no flow” refers to the point at which the air/nitrogen output pressure is 0 PSI. The Air America® Guardian™ universal tester should be utilized to monitor the various pressure adjustments that are necessary to accurately tune your marker and system.

Step 3. Connect the Raptor® air system to the marker: if applicable, to the secondary regulator and then to the marker.

Step 4. Slowly increase the regulated output pressure to the marker, until you reach the point at which you have enough pressure to operate the re-cock system to effectively cock the marker.

Step 5. Stop and readjust the re-cock pressure on the marker using the Autococker front mount adjustable (Rock) regulator.

- Step 6. Load the marker with paint and begin to chronograph each of your shots. You will be increasing the output pressure of your secondary regulator in a dual staged system, or the output pressure of your Raptor® in a single staged system in ¼ turn increments. Following each ¼ turn increase shoot a string of three shots over the chronograph taking an average of the three shots. This will allow the internal pressure of the marker to stabilize and for you to get a “feel” for the typical velocity increase per ¼ turn.
- Step 7. Continue to do this until the increase becomes nominal or maybe even a decrease in velocity is noted. This is your balance point between air chamber pressure and hammer spring energy. Leave the regulator set at this point.
- Step 8. For final velocity adjustment, go to the adjuster on the back of the marker. Adjust the hammer spring in only enough to achieve the desired velocity for field use.

NOTE: If you cannot achieve the desired velocity by adjusting the hammer spring energy; then you may need to alter the spring energy of either the hammer or the exhaust valve on your marker. Once you have changed your spring setting you will be required to re-balance the air chamber pressure by retracing steps 6, 7, and 8. Once you have achieved a balance between air chamber pressure and hammer spring energy, never increase air chamber pressure without making a corresponding increase in hammer spring energy.

The importance of a “balanced” set of springs working inside your marker is illustrated by this tuning procedure. The gas pressure in the air chamber of the valve acts as a spring just as the remainder of the mechanical springs in your marker does. Any change in air delivery pressure must be counteracted with a corresponding altering of the effected mechanical spring energy.