

 azodin®
www.azodin.com



ZENITH®

.68 CALIBER ELECTRONIC PAINTBALL MARKER

OWNERS MANUAL

SPECIFICATION

WEIGHT:

1,155 G/ 2.55 LBS/ 40.74 OZ

LENGTH:

528 MM/ 20.79 IN

HEIGHT:

240.3 MM/ 9.47 IN

WIDTH:

35 MM/ 1.38 IN

BARREL THREAD:

INTERCHANGEABLE WITH AUTOCOCKER THREAD BARREL

FEEDNECK THREAD:

INTERCHANGEABLE WITH ION/ IMPULSE THREAD FEEDNECK

LOW PRESSURE INLINE REGULATOR:

STANDARD ASA THREAD

ON/ OFF BOTTOM ASA:

STANDARD DOVETAIL MOUNT

CONTENTS

SAFETY INSTRUCTION AND GUIDELINES	P.1-4
GETTING STARTED	P.5-6
USING THE ZEN BOARD	P.7-8
VELOCITY ADJUSTMENT	P.9
REGULATOR ADJUSTMENT	P.10-11
ZERO SYSTEM - INSTRUCTION AND ADJUSTMENT	P.12-13
ASSEMBLY AND CLEANING THE MARKER	P.14-15
REASSEMBLE REAR INTERNALS	P.16
TROUBLESHOOTING	P.17
ZENITH SCREW CHART	P.18-19
ZENITH O-RING CHART	P.20-22
ZeRO SYSTEM EXPLODED VIEW	P.23
INLINE REGULATOR EXPLODED VIEW	P.24
ON/OFF BOTTOM ASA EXPLODED VIEW	P.25
ZENITH PART LIST	P.26
ZENITH EXPLODED VIEW	P.27

! WARNING !

IMPORTANT SAFETY INSTRUCTION AND GUIDELINES

- This Paintball Marker is NOT A TOY. Misuse can cause serious injury or death.
- Recommend 18 years or older to purchase this product. Person under 18 must have adult supervision.
- Read this manual, understand and follow the manual instructions for using this product.
- Eye and face protection specially designed for paintball use, must be worn by user and persons within range at all times.
- Treat all paintball markers as if it were loaded and able to fire.
- Never look down the barrel or breech area of a marker.
- Always use barrel blocking device when the marker is not in use.
- Always chronograph this marker before playing paintball.
- Never shoot any marker at velocities exceeds 300 FPS (Feet Per Second), or velocities which is greater than local fields or national laws allow.
- Always chronograph the marker before playing.

! WARNING !

IMPORTANT SAFETY INSTRUCTION AND GUIDELINES

- Ensure all air lines and fittings are tightened and secured before installing the air tanks.
- Do not shoot at people, animals, houses, cars or anything is not related to the sport of paintball.
- Always keep the marker in Safe mode until ready for use.
- Fire only 0.68 caliber paintballs with this marker.
- Always make sure the bolt is in the un-cocked position when marker is not in use.
- Any modifications or tampering of original factory parts will void all warranties and liabilities from Azodin LLC.
- This owner's manual should always accompany this marker for reference and in the event of resale and new ownership.

! WARNING !

IMPORTANT CO2/ HPA AIR TANK SAFETY INSTRUCTION AND GUIDELINES

- Tank valves must be installed or removed by qualified personnel.
- All tanks must be retested before the expiration date. ®
- Improper use, filling, storage of this air tank may cause death, serious injury and property damage.
- Air tanks must be filled only by properly trained personnel.
- Do not over pressurize. Do not expose pressurized tanks to temperatures in excess of 130F° degrees (54°C).
- Do not expose tanks to corrosive materials and do not clean with caustic cleaners.
- Do not alter tanks in any way.
- Tanks heated up to a temperature of 250F° degrees (54°C) or more must be condemned or re-qualified.
- Keep air tanks out of reach of children.
- The valve should NEVER detach from the tank canister. Should this occur, seek assistance from a qualified airsmith immediately.
- Air tanks are use for the sport of paintball only.

! WARNING !

IMPORTANT CO2/ HPA AIR TANK SAFETY INSTRUCTION AND GUIDELINES

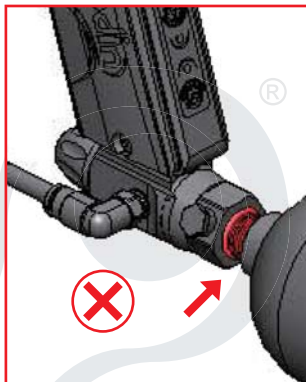
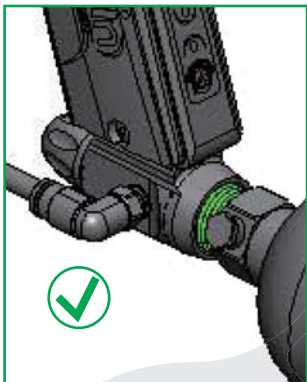

STOP IMMEDIATELY

CO2 or HPA/ N2 Air tanks will have enough force to fly off and cause serious injury or death if the valve unscrews from the tank head.

Look at the valve when removing the tank from the marker's **On/Off Bottom ASA (A091)**. Make sure that the valve is turning with the tank instead of staying with the marker.

STOP IMMEDIATELY if valve starts to unscrew from the tank itself. Screw the tank back onto the marker's On/Off Bottom ASA adapter and contact a qualified airsmith for further assistance.

GETTING STARTED

1. First, place the BARREL BLOCKING DEVICE over the barrel.
2. Always point your marker at a “SAFE” direction before use. [®]
To use, press the Top Button once on the back of the grip frame. Doing this the Upper LED will show **Red Light** and the marker will be in Safe Mode. To unlock from the Safe Mode, point the marker in a Safe Direction, and press the Bottom Button once. Doing this the Upper LED will show **Green Light** and the marker will be ready to play.

* For detailed operation of the electronics please refer to page (7)

3. Firmly screw in the CO2/ HPA/ N2 air tank to the **On/Off Bottom ASA (A091)**. Tighten the air tank clockwise all the way in the marker's On/Off Bottom ASA.

CAUTION: Never use any hand tool to screw air tank to the bottom ASA.

4. Attach a paintball hopper/ loader to the marker's feed neck.
5. Remove the barrel blocking device and unlock the safe mode.
CAUTION: Now the marker is LIVE, pulling the trigger will fire a paintball. Only test your marker at the safe direction or in a proper organized paintball field.

6. Check marker's velocity FPS (Feet Per Second). Turning the **Velocity Adjuster (P023)** clockwise will increase the velocity. Counterclockwise will decrease the velocity.
7. After playing, take out all paintballs from the hopper. Then detach the hopper from the marker.
CAUTION: There may be 1-2 paintballs in the breach area; take a couple more shots in a safe direction to make sure the marker is empty of paintballs.
8. Place the barrel blocking device over the barrel and push the safety button in the safe mode.
9. Unscrew the CO2/ HPA/ N2 air tanks from the marker's bottom ASA.
CAUTION: Never use any hand tool to screw air tanks to the bottom ASA.
10. Store the marker in a paintball bag or in a safe place.

USING THE ZEN BOARD

TO TURN ON THE BOARD: Press the Top Button once to turn on the board. Upper LED will show **Red Light (Safe Mode)** and Lower LED will show **Green Light (Default setting is Semi-Auto mode)** or your previous setting **(The ZEN Board will memorize last setting of shooting mode).**

If Upper LED Light is flashing **Red Light**, it means battery power status is low and the battery needs to be change. Battery power status can be verified by press Top Button once more to confirm.

SAFE MODE: After turning on the board, press Bottom Button once to turn off the Safe Mode and Upper LED Light will show **Green Light** to indicate the Eyes are on.

Press Bottom Button again to turn on the Safe Mode. Right now the Upper LED Light will show **Red Light** to indicate the Safe Mode is on.

EYES ON/OFF: When Safety is on and Upper LED Light is showing **Green Light (Eyes On)**. Press the Top Button once and Upper LED Light will change to **Change Light** to indicate the eyes are off. To turn the eyes back On, Press Top Button again and Upper LED Light will showing **Green Light** again to indicate the Eyes are back on. When there is a ball break or Eyes are malfunction, Upper LED Light will **flash Green Light**. Now press Top Button to turn off the Eyes and press Top Button again to turn the back Eyes on to determine the problem. If the Upper LED light still **flash Green Light**, clean out the Eyes.

LED COLORS

UPPER LED

RED = SAFE MODE

GREEN = EYES ON

ORANGE = EYES OFF (11.1 BPS)

FLASH RED = LOW BATTERY POWER STATUS

FLASH GREEN = EYES MALFUNCTION (8 BPS)

LOWER LED

GREEN = SEMI-AUTO (20 BPS)

DARK BLUE = PSP RAMP (13.1 BPS)

PURPLE = MILLENIUM RAMP (12 BPS)

LIGHT BLUE = CFOA SEMI (13.1 BPS)

FLASH GREEN = PROGRAMMING MODE

BUTTONS

TOP BUTTON

PRESS ONCE = POWER ON

PRESS AGAIN = VERIFY BATTERY POWER STATUS

PRESS AGAIN = EYES ON/OFF

PRESS AND HOLD = TURN OFF

BOTTOM BUTTON

PRESS ONCE = SAFE MODE ON/OFF

PRESS AND HOLD = ENTERS PROGRAMMING MODE

IN PROGRAMMING MODE

PRESS ONCE = CYCLE THROUGH SHOOTING MODES

PRESS AND HOLD = CONFIRM SHOOTING MODES

***ZEN Board will memorize last setting of shooting mode**

VELOCITY ADJUSTMENTS

(INCREASE & DECREASE VELOCITY)



To increase your velocity FPS (Feet Per Second), use the allen wrench to turn the [Velocity Adjuster \(P023\)](#) clockwise.

To decrease your velocity FPS (Feet Per Second), use the allen wrench to turn the [Velocity Adjuster \(P023\)](#) counterclockwise.

REGULATOR ADJUSTMENT

(INCREASE & DECREASE AIR PRESSURE)

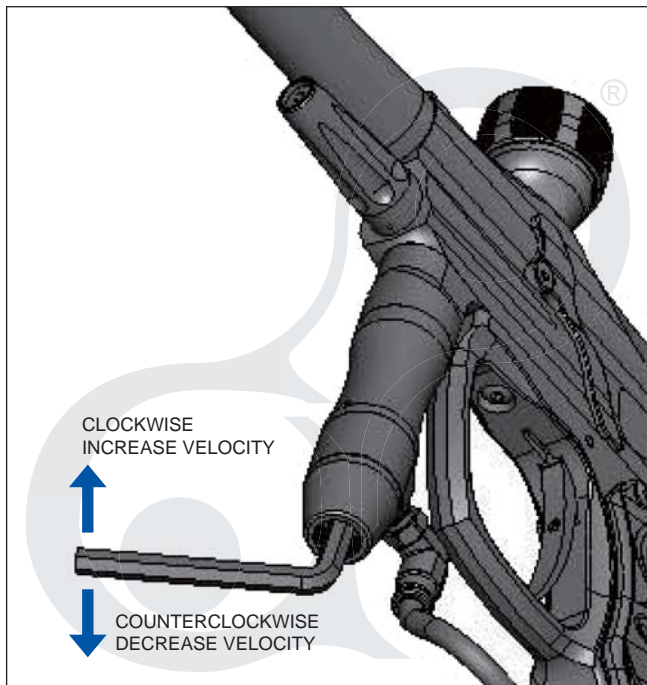

To increase the input pressure use the allen wrench to turn the **Regulator Adjustment Screw (S032)** clockwise.

To decrease the input pressure use the allen wrench to turn the **Regulator Adjustment Screw (S032)** counterclockwise.

NOTE: Regulator is preset at the factory for optimum performance. Fine adjustment of velocity should be done with the [Velocity Adjustor \(P023\)](#) on page 9.

NOTE: Each quarter turn correspond to approximate increase or decrease of 20psi.



ZeRO SYSTEM

INSTRUCTION AND ADJUSTMENT

WARNING: Never remove the internal of the marker while the air tank is attached with the marker.

FOR CO2 OPERATION:

NOTE: Zenith is optimized for use with HPA, in order to optimize the Zenith for CO2 use, please follow the instructions below.

1. Insert the 3mm allen wrench into the ZeRO Adjustment Screw (Z001). Turn clockwise two full revolutions.
2. To optimize the velocity, make sure the rear velocity adjustment is backed all the way out. Adjust the Inline Regulator (refer to Regulator Adjustment) until the marker is shooting at 250 feet per second over a chronograph.
3. To fine-tune the marker velocity follow the direction on page 9 (refer to Velocity Adjustment)

FOR HPA OPERATION:

NOTE: Zenith is optimized for HPA use out of the box. Follow the instructions below only after you have used the CO2 setting and would like to reconfigure for HPA use.

1. Insert the 3mm allen wrench into the ZeRO Adjustment Screw (Z001). Turn counter-clockwise two full revolutions.

2. To optimize the velocity, make sure the rear velocity adjustment is backed all the way out. Adjust the Inline Regulator (refer to Regulator Adjustment) until the marker is shooting at 250 feet per second over a chronograph.
3. To fine-tune the marker velocity follow the direction on page 9 (refer to Velocity Adjustment)

ADVANCE ADJUSTMENT:

The ZeRO System is a revolutionary combination of the Feather Striker and a redesign of the Valve Engine. The ZeRO System is designed to reduce Mechanical Recoil to a minimum by balancing the output pressure of the Inline Regulator with the timing of the ZeRO System.

NOTE: The instructions below are for fine-tuning of the ZeRO System. Do not attempt unless you have a thorough understanding of the ZeRO System operation.

1. Insert the 3 mm allen wrench into the ZeRO Adjustment Screw (Z001).
2. Turning Clockwise will tighten the ZeRO Spring to decrease valve timing. Refer to Step 2 and 3 from above to fine-tune velocity.

NOTE: Decrease valve timing will increase air efficiency but it will cause an increase in mechanical recoil.

3. Turning Counter-Clockwise will loosen the ZeRO to increase valve timing. Refer to Step 2 and 3 from above to fine-tune velocity.

NOTE: Increase valve timing will decrease air efficiency but it will cause a decrease in mechanical recoil.

ASSEMBLY AND CLEANING

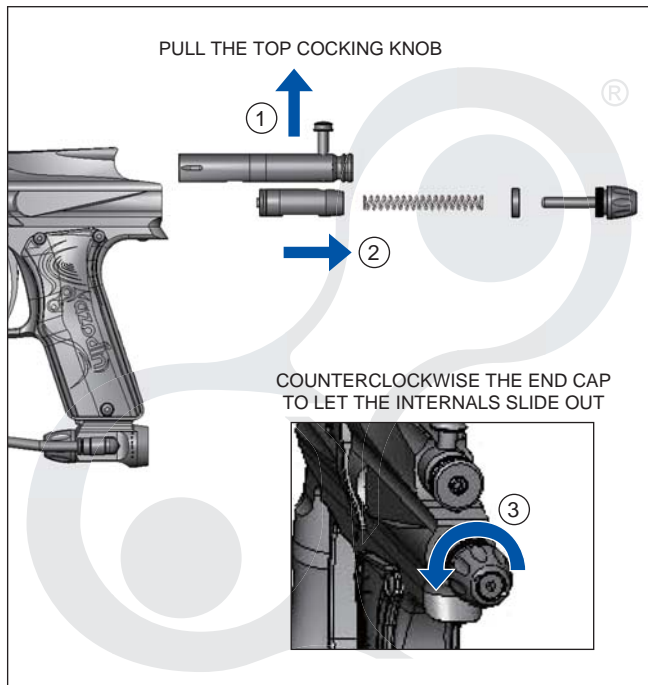

WARNING: Never remove the internals of the marker while the air tank is attached with the marker. Always remove all paintballs, loader and air tank before disassembling the marker.

CLEANING AND DISASSEMBLE REAR INTERNALS

1. Lift upward on the Top Cocking Knob at the rear of Delrin Bolt. This will let the **Delrin Bolt (P041)** slide out from the rear of the receiver.
2. Turn the **End Cap (A051)** counterclockwise. This will let the End Cap and the marker's internals to slide out from the rear of the receiver. Remember to place the marker in the de-cock position and place light pressure behind the End Cap during the removal of the End Cap, this way will prevent the internals to spring out.
3. Slide the **Feather Striker (P021)** out of the rear of the receiver.
4. Once all the internal parts are removed, use a squeegee to clean the inside of the receiver and use a towel to clean the dirt or paint off of Delrin bolt. Apply some paintball gun oil on the Striker O-Ring regularly.

REASSEMBLE REAR INTERNALS

1. Insert the **Feather Striker (P021)** thru the rear of the receiver with the O-Ring facing towards the front of the marker and with the hole on the Feather Striker facing upright. While inserting the Feather Striker, apply pressure behind the Feather Striker and at the same time pull the Trigger to let Feather Striker enter the rear chamber of the receiver.
2. Insert the **Feather Bumper (P024)** thru the receiver and insert the **ZeRO Feather Spring (P025)** thru the Feather Bumper.
3. Insert the **End Cap (A051)** with the **Velocity Adjuster (P023)** Thru the Feather Bumper and Feather Spring.
4. Turn the **End Cap (A051)** clockwise to tighten it and hold the internals in place.
5. Insert the **Bolt Assembly (P041)** thru the rear of the receiver. Press downward on the Top Cocking Knob (At the rear of Bolt Assembly) to connect and enter the hole of Feather Striker to fasten with the Feather Striker. Use a small tool such as allen wrench to align the hole of the Feather Striker.

TROUBLESHOOTING

WARNING: Always remove all paintballs, loader and air tank before disassembling the marker.

RECOCKING ISSUES

Need Lubrication on the **Striker O-Ring (R011)**.

Striker O-Ring is damaged or missing. Replace a correct O-Ring.

The pressure in the tank is too low and needed to be refilled.

Dirt or broken paintball shell fragments in the receiver. Check, cleaning, and disassemble rear internals.

AIR LEAKS

Air leaking from the low pressure chamber. Check **AZ O-Ring (R015)**, replace or need to be oiled.

Air leaking from under the barrel is normally caused by worn or damaged **ZeRO Cup Seal (R013)**. Check the guide for removal of Cup Seal / Valve Body.

A scratch on the Valve Body will cause air leak.

Air leaking from the receiver and throughout the Grip frame. Check Valve O-Rings and replace.

ZENITH SCREW CHART
SIZE: 1:1

PART NUMBER AND NAME



S011 M5 X 10L
MAIN BODY SCREW



S012 M8 X 8L
VALVE RETAINING SCREW



S016 M4 X 8L
GRIP PANEL SCREW



S017 M5 X 14L
VERTICAL ASA SCREW



S018 M4 X 8L
EYE COVER SCREW



S031 M4 X 4
REGULATOR RETAINING
SCREW

ZENITH SCREW CHART
SIZE: 1:1

PART NUMBER AND NAME



S032 M12 X 8L
REGULATOR ADJUSTMENT
SCREW



S091
ON/OFF BOTTOM ASA
RETAINING SCREW







S092 1/8-27 NPT
ON/OFF BOTTOM ASA
HOSE PLUG

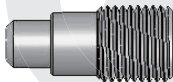



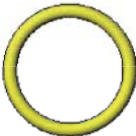



S093 M5 X 12L
ON/OFF BOTTOM ASA SCREW



Z031
ZeRO ADJUSTMENT SCREW

ZENITH O-RING CHART SIZE: 1:1	PART NUMBER AND NAME
	<p>R011 STRIKER O-RING (RED)</p>
	<p>R012 FRONT VALVE O-RING (CLEAR)</p>
	<p>R013 VELOCITY ADJUSTER O-RING (BLACK)</p>
	<p>R015 AZ O-RING (BLACK)</p>
	<p>R016 BARREL O-RING (BLACK)</p>

ZENITH O-RING CHART SIZE: 1:1	PART NUMBER AND NAME
	<p>R017 END CAP O-RING (BLACK)</p>
	<p>R031 REGULATOR PISTON O-RING (CLEAR)</p>
	<p>R032 REGULATOR SWIVEL MOUNT O-RING (BLACK)</p>
	<p>R033 REGULATOR INNER O-RING (CLEAR)</p>
	<p>R034 REGULATOR SEAL O-RING (CLEAR)</p>

ZENITH O-RING CHART SIZE: 1:1	PART NUMBER AND NAME
	<p data-bbox="467 263 871 369">R091 ON/OFF BOTTOM ASA O-RING (CLEAR)</p> <p data-bbox="467 492 798 598">Z021 ZeRO CUP SEAL O-RING (CLEAR)</p> 

Z001 ZeRO SYSTEM

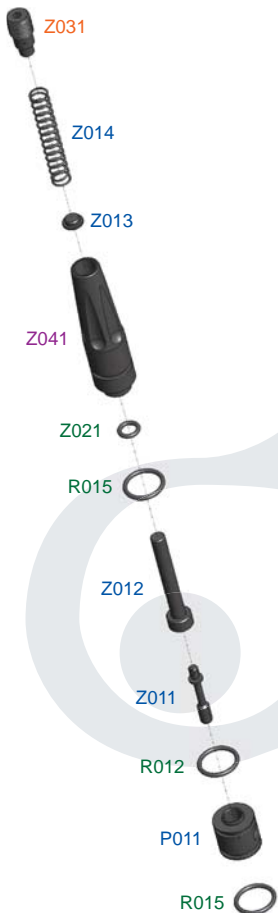

ZeRO SYSTEM PARTS LIST

NO	PART NAME
P011	VALVE
Z011	ZeRO CUP SEAL STEM
Z012	ZeRO CUP SEAL
Z013	ZeRO SPRING GUIDE
Z014	ZeRO SPRING
R012	FRONT VALVE O-RING (CLEAR)
R015	AZ O-RING
Z021	ZeRO CUP SEAL O-RING
Z031	ZeRO ADJUSTMENT SCREW
Z041	ZeRO HOUSING

A062 INLINE REGULATOR

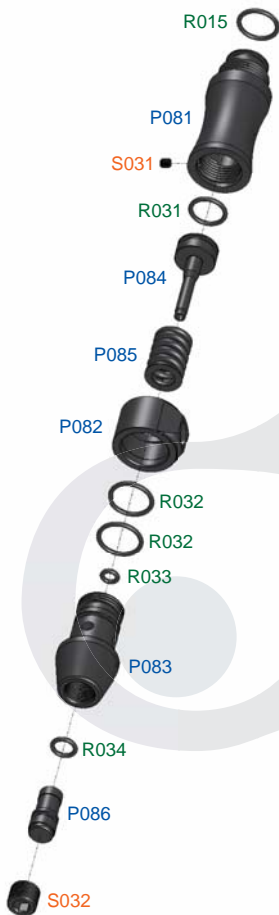

REGULATOR PARTS LIST

NO	PART NAME
P081	MAIN REGULATOR HOUSING
P082	REGULATOR SWIVEL MOUNT
P083	REGULATOR END CAP
P084	REGULATOR PISTON
P085	REGULATOR MAIN SPRING
P086	SEAT SEAL CARRIER
R015	AZ O-RING
R031	REGULATOR PISTON O-RING
R032	REGULATOR SWIVEL MOUNT O-RING
R033	REGULATOR INNER O-RING
R034	REGULATOR SEAL O-RING
S031	REGULATOR RETAINING SCREW
S032	REGULATOR ADJUSTMENT SCREW

A091 ON/OFF BOTTOM ASA



ON/OFF BOTTOM ASA PARTS LIST

NO	PART NAME
P063	90 DEGREE MACROLINE HOSE
P091	ON/OFF BOTTOM ASA STEM
R091	ON/OFF BOTTOM ASA O-RING
S091	ON/OFF BOTTOM ASA RETAINING SCREW
S092	ON/OFF BOTTOM ASA HOSE PLUG
A092	ON/OFF BOTTOM ASA CAP
A093	ON/OFF BOTTOM ASA MAIN BODY

ZENITH PARTS LIST

NO	PART NAME	NO	PART NAME
P011	VALVE	S011	MAIN BODY SCREW
P021	FEATHER STRIKER	S012	VALVE RETAINING SCREW
P023	VELOCITY ADJUSTER	S016	GRIP PANEL SCREW
P024	FEATHER BUMPER	S017	VERTICAL ASA [®] SCREW
P025	ZERO FEATHER SPRING	S018	EYE COVER SCREW
P031	BALL DETENT	S093	ON/OFF BOTTOM ASA SCREW
P033	EYE COVERS		
P042	BOLT ASSEMBLY		
P051	TWIST LOCK FEEDNECK	A013	ZENITH BODY
P063	90 DEGREE MACROLINE ELBOW	A032	VERTICAL ASA
P073	ZENITH MACROLINE HOSE	A051	END CAP
		A062	INLINE REGULATOR
		A072	E-GRIP FRAME ASSEMBLY
R011	STRIKER O-RING (RED)	A082	GRIP PANEL
R013	VELOCITY ADJUSTER O-RING	A091	ON/OFF BOTTOM ASA
R015	AZ O-RING	A211	5" .689 BARREL BACK
R016	BARREL O-RING	A221	9" BARREL FRONT
R017	END CAP O-RING	Z001	ZeRO SYSTEM

ZENITH EXPLODED VIEW

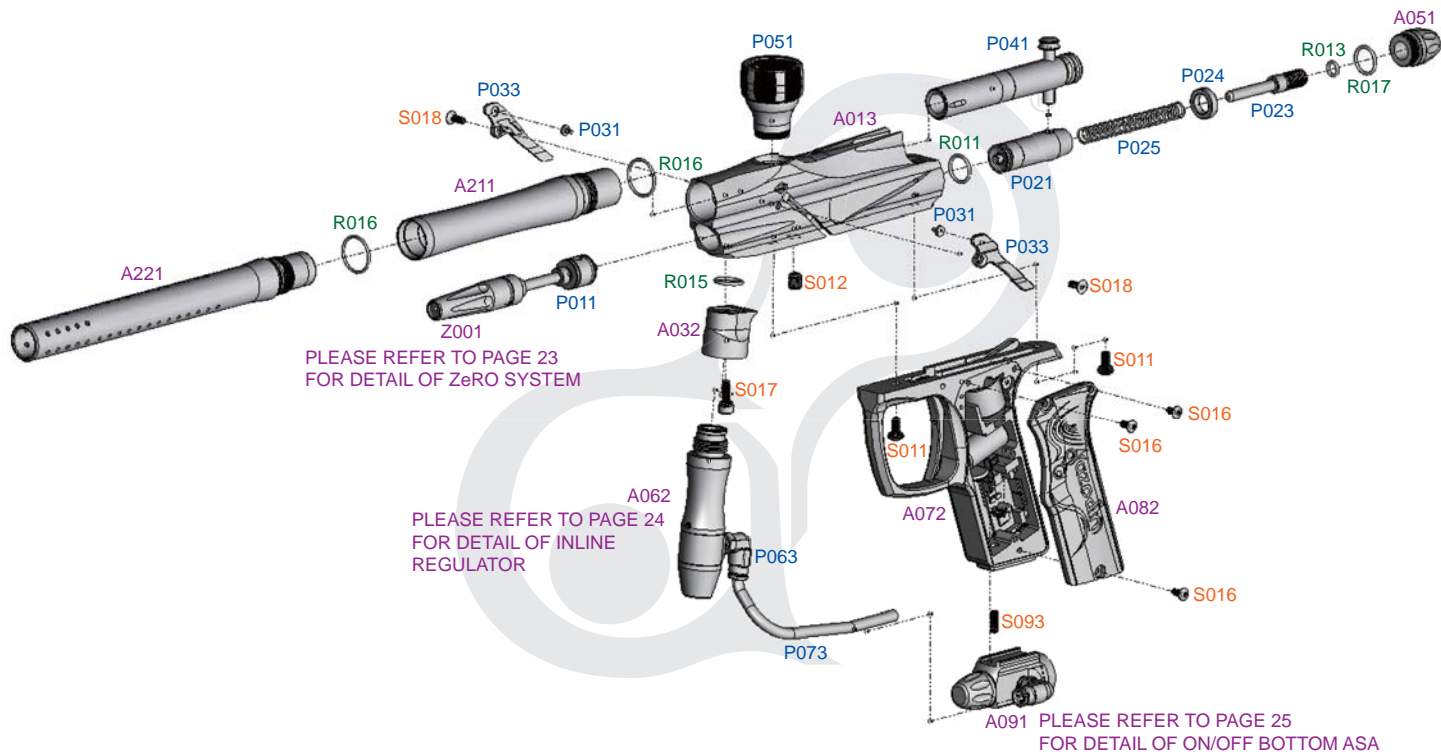

www.azodin.com



Azodin LLC
2405-A Linn Ave. South El Monte, CA 91733, USA
TEL: 626-350-7000 FAX: 626-350-7001